

EKG Lab Report
Assessment Design, Implementation, and Analysis
Doug Lownsbery
July 21, 2013

Revisions for the 2013 Winter Term

The RLC Circuits and the Electrocardiogram Lab (EKG Lab) was the last of eight weekly labs conducted as part of the General Physics course during the 2013 Winter Term at Portland State University. The approximately 2 hour and 50 minute lab was conducted during 20 sessions serving approximately 440 students throughout the last week of February 2013. The lab sessions were conducted by 14 different graduate student Teacher Assistants (TAs) under the direction of the Laboratory Coordinator and Physics Professor, Dr. Ralf Widenhorn.

For the Winter 2013 course, the Research Team reviewed and reviewed the learning goals and assessment instruments that had been used during the 2012 Spring Term of the same course. The learning goals and assessment instruments were revised to accomplish the following goals:

- ◆ increase the alignment between the learning goals and the Laboratory Manual
- ◆ increase the alignment between the learning goals and the assessment instruments
- ◆ increase the alignment between the different assessment instruments used
- ◆ increase the depth of the content and skills assessed

To increase the alignment between the learning goals and the Laboratory Manual, the learning goals were significantly revised to more closely reflect the key content and skills in the investigations conducted during the lab session. To increase the alignment between the learning goals and the assessment instruments, some prior assessment items were deleted and some items were revised based on key content and skills defined in the learning goals and based on the assessment results from the Spring 2012 administration. In addition, some new items were added to address gaps in the sampling of content and skills.

Four different assessment instruments were used during the EKG Lab (Online Quiz, Pretest/Posttest, Laboratory Manual questions, and Lab Exam). To increase the alignment between the different assessment instruments, key concepts and skills were assessed in similar, but slightly different, ways in the different instruments. The intent of this design was to provide a more complete picture of student learning before, immediately after, and two weeks after completing the EKG Lab. To increase the depth of content and skills assessed, the 2013 Winter administration included a number of open-response items in the Pretest/Posttest and Lab Exam. The open-response items allowed for increased probing of students' understanding and skills including explaining their answers, drawing and labeling diagrams, and showing their work when using equations.

Learning Goals

Based on a review of the RLC Circuits and the Electrocardiogram Laboratory Manual, the Research Team identified the following five learning goals:

1. An EKG sensor measures and amplifies output signals from the heart in the magnitude of millivolts in the approximate frequency range of 1 Hz to 20 Hz.
2. An EKG sensor functions as a band-pass filter to filter out environmental noise and to attenuate frequencies above and below the range of the human heart.
3. An AC circuit with a function generator, inductor, and capacitor can act as a band-pass filter.
4. In an AC circuit, the inductor functions as a low-pass filter that allows low frequency signals to pass through and attenuates high-frequency signals. The capacitor functions as a high-pass filter that allows high-frequency signals to pass through and attenuates low-frequency signals.
5. In an AC circuit, the equation below can be used to calculate the value of the resonant frequency.

$$f = \frac{1}{2\pi\sqrt{LC}}$$

Appendix A shows the alignment between the Learning Goals and the Online Quiz, Pretest/Posttest, and Lab Exam instruments.

Assessment Instruments

Online Quiz

The Online Quiz was administered the week before and the week after the EKG Lab. The Online Quiz was composed of three multiple-choice questions. The purpose of the Online Quiz was to direct students to read through the Laboratory Manual prior to the actual lab session and to provide a minor follow-up after the session. Student responses were scored immediately by the online system as either correct or incorrect, and students had unlimited opportunities to try to answer an item correctly. Using this system, all students who completed the Online Quiz eventually answered all three items correctly. Results from the Online Quiz are not included in this report. Students received minor credit extra in the course for completing the Online Quiz.

Appendix B shows the three items used in the Online Quiz.

EKG Lab Pretest/Posttest

Identical pretests and posttests were administered before and after the EKG Lab session. A draft version of the EKG Lab Pretest/Posttest was first administered to the graduate student TAs for review and comment during their orientation session for the EKG Lab. The TAs took the Pretest/Posttest independently and anonymously, and then the entire group discussed the accuracy and clarity of the questions, answer choices, and prompts, as well as the spectrum of responses that were provided for the open-response items. Revisions resulting from that review

were incorporated in the final Pretest/Posttest. The final Pretest/Posttest included four multiple-choice items and three open-response items. After answering each item, students were asked to rate their confidence in their answer using a scale from 1-5, with (1) being Not Confident, (3) being Neutral, and (5) being Confident. *Appendix C* shows the seven items used in the EKG Lab Pretest/Posttest.

Because the EKG Lab was a relatively long lab that could fill the allotted 2 hour and 50 minute period, the EKG Lab Pretest was administered at the end of the prior lab session. Students were told that the Pretest was part of a research study and that their scores would not affect their course grades. Students were encouraged to take the necessary time to answer each item to the best of their ability even though they had not yet completed the EKG Lab. The EKG Lab Posttest was administered immediately after students had completed all of the exercises in their EKG Laboratory Manual. Students were again told that the Posttest was part of a research study and that their scores would not affect their course grades. Students were instructed to complete the Posttest independently and without referencing their just completed Lab Report notebook. The Pretest and Posttest were scored by the Research Team. The scoring process used for the open-response items is described in the **Scoring** section of this report.

Laboratory Manual Questions

Each exercise in the EKG Laboratory Manual had an associated set of open-response questions totaling 19 questions. The Laboratory Manual questions were answered as the student completed each exercise and recorded their responses in a Lab Report notebook. Students worked both independently and collaboratively to answer the questions. Students were informed that their Lab Report notebooks contributed significantly to their laboratory grade. The responses were scored by the graduate student TAs. Results from the Laboratory Manual Questions are not included in this report. However, additional studies may be conducted using a sample of Lab Notebooks for the EKG Lab questions. The Lab Coordinator asked each TA to make copies of three Lab Notebooks from each lab section for possible later rescoring by the Research Team. The TAs were asked to make copies that represented at least one male and one female in each session and one each of relatively high scoring, medium scoring, and low scoring students on the 19 EKG Lab questions.

Lab Exam

The Lab Exam covered all eight Labs in the course and was administered two weeks after the last lab, the EKG Lab, and one week before the Final Exam for the General Physics course. The Lab Exam was composed of both multiple-choice and open-response items. In the Lab Exam, the EKG Lab was represented by three open-response items that were administered at the end of the test. All students took these same three items addressing the EKG Lab. The other 15 items in the Lab Exam were selected by each TA from a pool of possible items addressing the other seven labs in the course. As a result, the first 15 items of the Lab Exam could differ from lab section to lab section, but the last three items addressing the EKG Lab were the same for all sections.

The administration format of the Lab Exam was determined by the TAs. Three formats were used - open book, closed book, and limited notes (e.g., 1 page of notes or a 5×7 card of notes). Students were informed that the Lab Exam contributed significantly to their laboratory grade.

The entire Lab Exam was scored by the TAs to determine students' course grades. The three open-response items addressing the EKG Lab were scored separately by the Research Team. *Appendix D* shows the three items EKG Lab items used in the Lab Exam.

Student Demographics

Demographic Survey

A voluntary Demographic Survey was administered to all students at the end of the Lab Exam. Students were told that the Demographic Survey was part of a research study and that their participation would not affect their course grades. In addition, students were informed in the Survey instructions that their names on the Survey document would be transferred to a number code and that their names would not be tied to their individual responses. The questions in the Demographic Survey were designed to provide information about the characteristics of the student population that may have a correlation to performance on the EKG Lab assessments including gender, college major and career goals, prior and concurrent science and math courses, and personal opinions about the EKG Lab. *Appendix F* shows the 13 questions in the Demographic Survey.

Student Sample for Analysis

Of the approximately 440 students enrolled in the General Physics Lab course, a subset of students were used in the data analysis of the results on the various EKG Lab assessment instruments. Because the assessment design was intended to provide a picture over time of the effect of the EKG lab relative to the learning goals, the Research Team determined that only those students for which a complete set of instruments was collected would be included in the analysis. A total of 216 students completed the Online Quizzes, Pretest, EKG Lab session, Posttest, Lab Exam, and Demographic Survey. *Appendix F* also shows the results of the survey for the sample of 216 students. There are a number of reasons why students enrolled in the course did not complete all of the assessment instruments analyzed for this report. Some students were simply absent for one or more components and the make-up documents were not processed in the same manner as the other study documents. Some students did not include their name on one or more of the documents. In addition, some components were not uniformly administered by the TAs, and so were not included in the analysis. Table 1 shows the characteristics of the sample for three primary attributes: gender, year in college, and concurrent enrollment in an algebra-based or calculus-based physics course. Not all percentages may sum to 100% due to rounding or blank responses.

Table 1. Characteristics of Student Sample

Gender	N	%
Male	144	67
Female	69	32
Decline to Respond	3	1
Year in College	N	%
Freshman	5	2
Sophomore	55	25
Junior	65	30

Senior	42	19
Post-baccalaureate	45	21
Type of Physics Course	N	%
Algebra-based	90	42
Calculus-based	123	57

Scoring Processes

As the open-response items were developed for the Pretest/Posttest and the Lab Exam, corresponding draft Scoring Rubrics and Scoring Notes were developed for each item. The Scoring Rubrics defined the point value for each level of understanding demonstrated in the response (e.g., minimal, limited, general, and thorough). The Scoring Notes defined a thorough response for each expectation stated in the prompt. Two-point, three-point, and four-point items and corresponding Scoring Rubrics and Notes were developed to match the complexity and depth of understanding and skills represented by the Learning Goals. The draft open-response items and corresponding Scoring Rubrics and Notes were extensively reviewed by the members of the Research Team. As revisions were made to the items, corresponding revisions were made to the Scoring Rubrics and Notes.

Following administration of the Pretest, Posttest, and Lab Exam, the Research Team selected a calibration set of 24 students for the total subset of 216 students (11%). The calibration set included students from a number of lab sessions and students that appeared to demonstrate a wide spectrum of responses. Student names were redacted from all documents and were assigned unique identification numbers. Three members of the Research Team, including two graduate student research assistants and one graduate student TA lab instructor, independently scored each open-response item using the draft scoring rubrics. The three scorers then met to discuss the scores assigned to each item for each student. A consensus score was reached for each item and revisions were made to the Scoring Rubrics and Notes to reflect the decisions made as a result of the calibration discussions. Following the calibration round of scoring, each scorer independently scored approximately one-third of the items for the remaining 192 students by applying the revised Scoring Rubrics and Notes resulting from the calibration scoring. *Appendix E* shows the revised Scoring Rubrics and Notes used to score the open-response items in the Pretest/Posttest and Lab Exam.

Assessment Results

Multiple-Choice Items

There were a total of four 1-point multiple-choice items on the Pretest and identical Posttest. A comparison of the percentage of students who answered each item correctly (percent correct) represents the change (growth) in understanding of key concepts as a result of the EKG Lab. Table 2 shows the Pretest and Posttest percent correct for each item and the students' level of confidence in their responses using the scale from 1-5, with (1) being Not Confident, (3) being Neutral, and (5) being Confident. Percents are shown for confidence ratings of 4 or 5. *Appendix G* provides a complete set of tables comparing the frequency distributions for scores on the multiple-choice items.

Table 2. Results of Multiple-Choice Items

Item Number	Pretest		Posttest	
	Correct	Confidence Rating 4 or 5	Correct	Confidence Rating 4 or 5
1	57%	14%	91%	85%
2	48%	7%	67%	56%
3	54%	4%	92%	72%
4	52%	9%	83%	56%

Open-Response Items

Three open-response items were administered on the Pretest and identical Posttest worth a total of 9 points on each test (one 2-point item, one 3-point item, and one 4-point item). Three open-response items were also administered on the Lab Exam worth a total of 9 points (one 2-point item, one 3-point item, and one 4-point item). A comparison of the Pretest and Posttest mean scores represents the change (growth) in understanding of key concepts as a result of the EKG Lab. Table 3 shows the Pretest and Posttest mean scores for each item, the percentage of blank responses, and the students' level of confidence in their responses. Table 4 shows the mean scores and percentage of blank responses for each Lab Exam item.

Table 3. Results for Pretest/Posttest Open-Response Items

Item Number	Point Value	Pretest			Posttest		
		Mean Score	Blank	Confidence Rating 4 or 5	Mean Score	Blank	Confidence Rating 4 or 5
5	4	0.35	62%	13%	3.49	4%	67%
6	2	0.12	72%	14%	0.84	6%	57%
7	3	0.32	60%	8%	0.92	21%	26%

A comparison of the Pretest and Posttest mean scores indicates a large gain for Item 5 (from 0.35 to 3.49) and modest gains for Items 6 and 7. The percentage of confidence ratings of 4 or 5 increased greatly for Items 5 and 6 and very moderately for Item 7. As might be expected with gains in mean scores and increases in confidence ratings, the percentages of blank responses decreased from Pretest to Posttest for each item.

Table 4. Results for Lab Exam Open-Response Items

Item Number	Point Value	Mean Score	Blank
1	3	2.11	0%
2	2	1.19	0%
3	4	2.42	7%

A comparison of mean scores on the Posttest shown in Table 3 and the Lab Exam shown in Table 4 indicates that students retained key concepts from the EKG Lab session that had occurred up to two weeks earlier. In addition, the mean scores on the Lab Exam are relatively

much higher, and the percentages of blank responses much lower, than on the Posttest. These differences may reflect the level of student effort on the two sets of items since the Posttest did not count toward the students' course grade and the Lab Exam counted significantly toward the course grade. *Appendix G* provides a complete set of tables comparing the frequency distributions for scores on all the open-response items.

Possible Additional Analyses

Additional statistical analyses can be conducted to determine item discrimination and paired t-tests can be used on the Pretest and Posttest items to determine pre-post significance, standard deviation, and standard error mean.

In addition, the collected assessment and demographic data allow for multiple linear regression analyses to determine potential correlations between multiple independent variables. For example, are there correlations between variables such as students' type of physics course (algebra-based or calculus-based), college major, or gender and their performance on the EKG Lab assessments?

Recommendations for Future Implementation

There are two primary recommendations for future implementation of the EKG Lab. The first recommendation is to establish a comparison test between instruction and lab activities covering RLC circuits in a more traditional non-contextualized presentation of key concepts with instruction and lab activities focusing on the EKG sensor as a practical and engaging application of the same key concepts. In this way, a study can more directly investigate the differences in student understanding resulting from the difference between the non-contextualized and contextualized formats for physics instruction and lab activities. The second recommendation is to utilize online administration formats for all of the assessment instruments and the Demographic Survey. This change would greatly reduce the handling of student documents and key entry of student responses and greatly enhance data accuracy, management, security, and analysis. In addition, software can be used to simplify the processes for scoring the open-response items.

Appendix A EKG Lab Learning Goals Mapped to Online Quiz, Pretest/Posttest, and Lab Exam

Goal 1. An EKG sensor measures and amplifies output signals from the heart in the magnitude of millivolts in the approximate frequency range of 1 Hz to 20 Hz.

Total Points Possible: 5 points

Online Quiz: Q2 (1 pt.)

Pre/Posttest: Q1 (1 pt.), Q2 (1 pt.), Q3 (1 pt.), Q4 (1 pt.)

Lab Exam:

Goal 2. An EKG sensor functions as a band-pass filter to filter out environmental noise and to attenuate frequencies above and below the range of the human heart.

Total Points Possible: 5 points

Online Quiz: Q3 (1 pt.)

Pre/Posttest: Q6 (2 pts.)

Lab Exam: Q2 (2 pts.)

Goal 3. An AC circuit with a function generator, inductor, and capacitor can act as a band-pass filter.

Total Points Possible: 8 points

Online Quiz: Q1 (1 pt.)

Pre/Posttest: Q5 (4 pts.)

Lab Exam: Q1 (3 pts.)

Goal 4. In an AC circuit, the inductor functions as a low-pass filter that allows low frequency signals to pass through and attenuates high-frequency signals. The capacitor functions as a high-pass filter that allows high-frequency signals to pass through and attenuates low-frequency signals.

Total Points Possible: 7 points

Online Quiz:

Pre/Posttest: Q5 (4 pts.)

Lab Exam: Q1 (3 pts.)

Goal 5. In an AC circuit, the equation below can be used to calculate the value of the resonant frequency.

$$f = \frac{1}{2\pi\sqrt{LC}}$$

Total Points Possible: 7 points

Online Quiz:

Pre/Posttest: Q7 (3 pts.)

Lab Exam: Q3 (4 pts.)

Appendix B EKG Online Quiz

1. An AC circuit with a resistor, capacitor, and inductor acts as a

- A. high-pass filter due to the influence of the resistor.
- B. voltage divider due to the influence of both the resistor and inductor.
- C. signal amplifier due to the influence of the capacitor.
- D. band-pass filter due to the influence of both the capacitor and the inductor. *

2. All of the following are functions of an EKG except

- A. measuring resistance. *
- B. measuring voltage differences.
- C. filtering out bias offsets.
- D. filtering out high frequency noise.

3. In the EKG lab, the EKG sensor has three leads (Red, Green, and Black). Which of the following describes the use of the Black lead in taking an EKG reading?

- A. to create a dipole
- B. to remove electrical noise *
- C. to detect depolarization
- D. to amplify electrical signals

Appendix C EKG Lab Pretest/Posttest

Name _____ Date _____ Lab Sec _____

Lab Instructor _____ Lecture Instructor _____

For questions 1 through 4 below, circle the correct answer.

1. What does the EKG measure and what order of magnitude are the measurements?

- A. Voltage in the range of volts
- B. Voltage in the range of millivolts *
- C. Current in the range of amps
- D. Current in the range of milliamps

	Confident		Neutral		Not Confident
I am confident in my answer.	5	4	3	2	1

2. What is the difference between an EKG sensor and a standard voltage probe used in the labs?

- A. An EKG sensor amplifies incoming signals. *
- B. An EKG sensor is unaffected by skeletal electrical signals.
- C. An EKG sensor measures both AC and DC signals.
- D. An EKG sensor measures a wider range of signal magnitude.

	Confident		Neutral		Not Confident
I am confident in my answer.	5	4	3	2	1

3. At what frequency range is EKG probe most sensitive to signal input?

- A. less than 0.1 Hz
- B. between 1 Hz and 20 Hz *
- C. between 200 Hz and 500 Hz
- D. greater than 500 Hz

	Confident		Neutral		Not Confident
I am confident in my answer.	5	4	3	2	1

4. To measure a potential signal from the heart, it is best to consider the signal as most similar to

- A. a DC generator at 1V.
- B. a DC generator at 1 mV.
- C. an AC generator at 1 Hz. *
- D. an AC generator at 100 Hz.

	Confident		Neutral		Not Confident
I am confident in my answer.	5	4	3	2	1

For prompts 5 through 7 below, provide your response in the space provided.

5. An EKG functions as a band-pass filter. Draw a diagram of a circuit that functions as a band-pass filter that includes circuit components you have used so far in the laboratory course. Identify the component that, acting alone, functions as a low-pass filter. Also identify the component that, acting alone, functions as a high-pass filter. (4 points)

I am confident in my answer. Confident Neutral Not Confident
5 4 3 2 1

6. Explain why it is important for an EKG to function as a band-pass filter. (2 points)

I am confident in my answer. Confident Neutral Not Confident
5 4 3 2 1

7. Using the formula below, give values for circuit components to design a band-pass filter with a resonant frequency of 1000 Hz. (3 points)

$$f = \frac{1}{2\pi\sqrt{LC}}$$

I am confident in my answer. Confident Neutral Not Confident
5 4 3 2 1

For EKG Lab Posttest Only

For questions A through C below, provide your response to help us improve the EKG lab.

A. After completing this lab, do you feel that you better understand how an EKG works?

(5 - Much better understanding to 1 - No additional understanding)

- 5
- 4
- 3
- 2
- 1

B. How interesting did you find the EKG lab?

(5 - Very interesting to 1 - Not at all interesting)

- 5
- 4
- 3
- 2
- 1

C. Do you have any comments or suggestions on how to improve the EKG lab?

Appendix D Physics Lab Exam, EKG Lab Items

Item 1

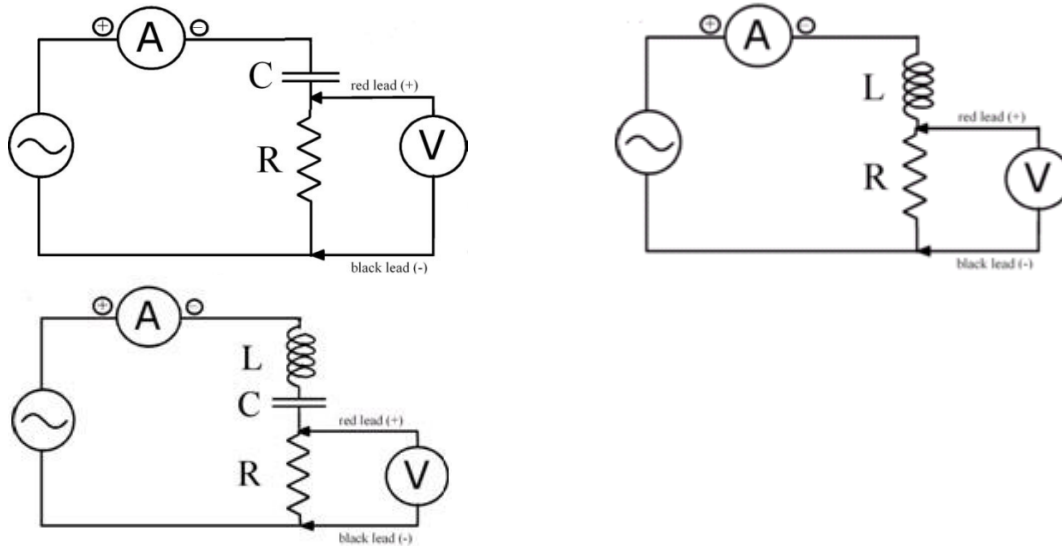

Which of the three circuits above serves as a (1) low-pass, (2) high pass, and (3) band pass filter for the voltage V ? Explain your reasoning. (3 points)

Item 2

Explain two reasons why an EKG probe functions as a band-pass filter. (2 points)

Item 3

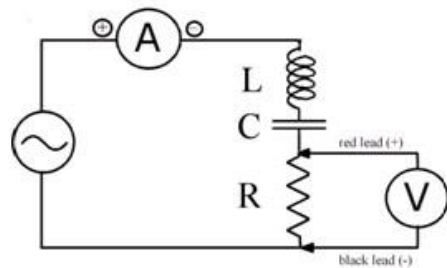

In the circuit above the inductor has a value of 50.0 mH, the resistor a resistance of 150 Ω , and the capacitor a capacitance of 200 μF .

Describe which parameters factor into the resonance frequency of the circuit. Explain your reasoning!

Calculate the value of the resonance frequency.

(4 points)

Appendix E Scoring Rubrics - Pretest/Posttest and Physics Lab Exam Open-Response Items

EKG Lab Pretest/Posttest Item 5	
An EKG functions as a band-pass filter. Draw a diagram of a circuit that functions as a band-pass filter that includes circuit components you have used so far in the laboratory course.	
Scoring Rubric	
4	The response demonstrates a thorough understanding.
3	The response demonstrates a general understanding.
2	The response demonstrates a limited understanding.
1	The response demonstrates a minimal understanding.
0	The response is incorrect or irrelevant to the skill or concept being measured.
B	The response is blank.
Scoring Notes	
<p>A complete response includes ALL of the following (1 pt. for each component): a diagram that shows a series circuit with</p> <ul style="list-style-type: none"> - a function generator (AC only, symbol for DC/battery is not acceptable) - a resistor - a capacitor - an inductor <p>Response can “show” components in a diagram by using conventional circuit component symbols only with or without labels.</p>	

EKG Lab Pretest/Posttest Item 6**Explain why it is important for an EKG to function as a band-pass filter.****Scoring Rubric**

2	The response demonstrates a thorough understanding.
1	The response demonstrates a limited understanding.
0	The response is incorrect or irrelevant to the skill or concept being measured.
B	The response is blank.

Scoring Notes

A complete response includes ANY TWO of the following:

- to filter out noise from other devices that generate electrical signals (1 pt.)
- to filter out low-frequency and high-frequency signals outside the intended range from the heart (1 pt.)
- to allow only the signals in the intended narrow range from the heart to pass through (1 pt.)

EKG Lab Pretest/Posttest Item 7**Using the formula below, give values for circuit components to design a band-pass filter with a resonant frequency of 1000 Hz.**

$$f = \pi LC$$

Scoring Rubric

3	The response demonstrates a thorough understanding.
2	The response demonstrates a general understanding.
1	The response demonstrates a limited understanding.
0	The response is incorrect or irrelevant to the skill or concept being measured.
B	The response is blank.

Scoring Notes

A complete response includes ALL of the following (1 pt. each):

- An inductor value given with units of henrys
- A capacitor value given with units of farads
- Numerical values for the inductor and capacitor that give $LC \approx 318.3$

Physics Lab Exam, Open Response Item 1 for EKG Lab

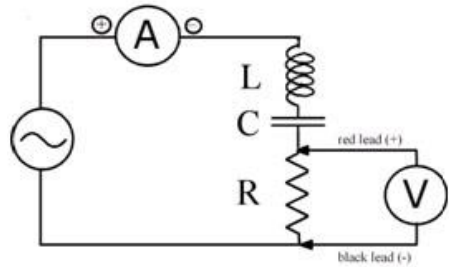
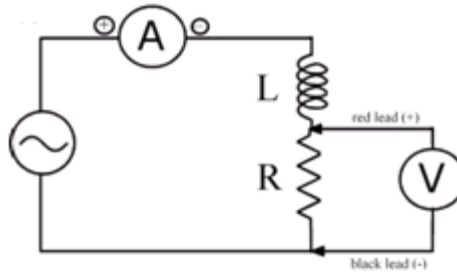
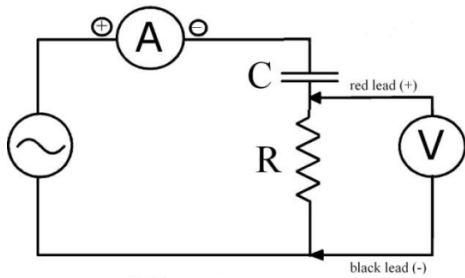

Which of the three circuits above serves as a (1) low-pass, (2) high pass, and (3) band pass filter for the voltage V ? Explain your reasoning.

Scoring Rubric

3	The response demonstrates a thorough understanding.
2	The response demonstrates a general understanding.
1	The response demonstrates a limited understanding.
0	The response is incorrect or irrelevant to the skill or concept being measured.
B	The response is blank.

Scoring Notes

A complete response includes ALL of the following: (0.5 pt. each)

- The circuit with an inductor and resistor only functions as a low-pass filter as configured.
- As configured, an inductor allows low-frequency signals to pass through and filters out high-frequency signals.
- The circuit with a capacitor and resistor only functions as a high-pass filter as configured.
- A capacitor allows high-frequency signals to pass through and filters out low-frequency signals.
- The circuit with both a capacitor and an inductor and a resistor functions as a band-pass filter as configured.
- As configured, a capacitor functions to filter high-frequency signals and an inductor functions to filter low-frequency signals, allowing only a band of frequencies to pass through.

Conversion from Points to Score (Final score must be whole numbers)

- .5 - 1.5 points = 1 (limited)
- 2.0 - 2.5 points = 2 (general)
- 3.0 points = 3 (thorough)

Physics Lab Exam, Open Response Item 2 for EKG Lab

Explain two reasons why an EKG probe functions as a band-pass filter.

Scoring Rubric

2	The response demonstrates a thorough understanding.
1	The response demonstrates a limited understanding.
0	The response is incorrect or irrelevant to the skill or concept being measured.
B	The response is blank.

Scoring Notes

A complete response includes ANY TWO of the following:

- to filter out noise from other devices that generate electrical signals (1 pt.)
- to filter out low-frequency and high-frequency signals outside the intended range from the heart (1 pt.)
- to allow only the signals in the intended narrow range from the heart to pass through (1 pt.)

No credit is given for portions of responses that give a 'smoother', 'amplified', or 'more readable' signal as reasoning for why the EKG probe functions as a band-pass filter.

Physics Lab Exam, Open Response Item 3 for EKG Lab

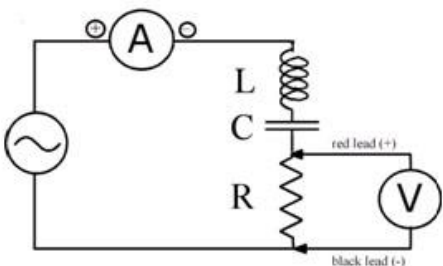

In the circuit above the inductor has a value of 50.0 mH, the resistor a resistance of 150 Ω , and the capacitor a capacitance of 200 μF .

Describe which parameters factor into the resonance frequency of the circuit. Explain your reasoning!

Calculate the value of the resonance frequency.

Scoring Rubric

4	The response demonstrates a thorough understanding.
3	The response demonstrates a general understanding.
2	The response demonstrates a limited understanding.
1	The response demonstrates a minimal understanding.
0	The response is incorrect or irrelevant to the skill or concept being measured.
B	The response is blank.

Scoring Notes

A complete response includes ALL of the following:

- Units of Hz, or 1/s, or rad/s (1 pt.)
- A value of 316 rad/s or 50.3 Hz (1 pt.)
- Equation for resonance frequency (either $\omega_0 = \frac{1}{\sqrt{LC}}$ or $f_0 = \frac{1}{2\pi\sqrt{LC}}$) (1 pt.)
- Resonance depends only on the capacitance and inductance of the circuit. The resistor value does not have a frequency response. Alternatively: Specify that resonance occurs when $X_L = X_C$, capacitive reactance = inductive reactance, or $2\pi fL = \frac{1}{2\pi fC}$ (1 pt.)

Appendix F Demographic Survey

Demographic Survey

Name* _____ Date: _____

*Your name will be transferred to a number code for this survey and will not be tied to your responses.

1. Demographics

- _____ Male
- _____ Female
- _____ Other: please list _____
- _____ Decline to respond

2. Year in College

- _____ Freshman
- _____ Sophomore
- _____ Junior
- _____ Senior
- _____ Post-bacc
- _____ Other: please list _____

3. What is your major? _____

4. What is your career goal? _____

5. Are you currently enrolled in algebra-based physics or calculus-based physics? (Choose one.)

- _____ Algebra-Based Physics
- _____ Calculus-Based Physics

6. What biology classes did you complete prior to this term? (Check all that apply.)

- _____ General Biology
- _____ Anatomy & Physiology
- _____ Cell Biology
- _____ Molecular Biology
- _____ Genetics
- _____ Other: please list _____

7. What chemistry classes did you complete prior to this term? (Check all that apply.)

- _____ General Chemistry
- _____ Organic Chemistry
- _____ Biochemistry
- _____ Physical Chemistry
- _____ Other: please list _____

Name _____ Date: _____

8. What physics classes did you complete prior to this term? (Check all that apply.)

- General Physics High School
- General Physics College
- Modern Physics
- Physics Workshop Leader
- Electron Microscopy
- Other: please list _____

9. What math classes did you complete prior to this term? (Check all that apply.)

- Math 111
- Math 112
- Calculus Prep Course (e.g. Calculus Head Start)
- Calculus I
- Calculus II
- Calculus III
- Calculus IV
- Linear Algebra
- Differential Equations
- Other: please list _____

In your opinion....

10. What lab was easiest to understand this term?

11. What lab was hardest to understand this term?

12. What lab did you learn the most from this term?

13. What lab was your favorite this term?

Thank you for your participation!

Appendix G EKG Lab Assessments - Comparisons of Frequency Distributions

Pretest/Posttest Multiple-Choice Items #1-4

Answer	Pre 1	
A	41	19.0%
*B	124	57.4%
C	17	7.9%
D	34	15.7%
Blank	0	0.0%
Sum	216	100.0%

Rating	PRE Confidence	
1	75	34.7%
2	37	17.1%
3	73	33.8%
4	22	10.2%
5	9	4.2%
Blank	0	0.0%
Sum	216	100.0%

Answer	Post 1	
A	15	6.9%
*B	197	91.2%
C	2	0.9%
D	2	0.9%
Blank	0	0.0%
Sum	216	100.0%

Rating	POST Confidence	
1	3	1.4%
2	2	0.9%
3	27	12.5%
4	49	22.7%
5	134	62.0%
Blank	1	0.5%
Sum	216	100.0%

Answer	Pre 2	
*A	103	47.7%
B	27	12.5%
C	46	21.3%
D	39	18.1%
Blank	1	0.5%
Sum	216	100.0%

Rating	PRE Confidence	
1	90	41.7%
2	48	22.2%
3	64	29.6%
4	10	4.6%
5	4	1.9%
Blank	0	0.0%
Sum	216	100.0%

Answer	Post 2	
*A	144	66.7%
B	36	16.7%
C	20	9.3%
D	14	6.5%
Blank	2	0.9%
Sum	216	100.0%

Rating	POST Confidence	
1	11	5.1%
2	11	5.1%
3	70	32.4%
4	60	27.8%
5	60	27.8%
Blank	4	1.9%
Sum	216	100.0%

Answer	Pre 3	
A	44	20.4%
*B	116	53.7%
C	39	18.1%
D	15	6.9%
Blank	2	0.9%
Sum	216	100.0%

Rating	PRE Confidence	
1	113	52.3%
2	43	19.9%
3	50	23.1%
4	4	1.9%
5	4	1.9%
Blank	2	0.9%
Sum	216	100.0%

Answer	Post 3	
A	8	3.7%
*B	198	91.7%
C	9	4.2%
D	0	0.0%
Blank	1	0.5%
Sum	216	100.0%

Rating	POST Confidence	
1	3	1.4%
2	7	3.2%
3	47	21.8%
4	69	31.9%
5	86	39.8%
Blank	4	1.9%
Sum	216	100.0%

Answer	Pre 4	
A	17	7.9%
B	61	28.2%
*C	112	51.9%
D	24	11.1%
Blank	2	0.9%
Sum	216	100.0%

Rating	PRE Confidence	
1	98	45.4%
2	42	19.4%
3	53	24.5%
4	15	6.9%
5	5	2.3%
Blank	3	1.4%
Sum	216	100.0%

Answer	Post 4	
A	5	2.3%
B	17	7.9%
*C	179	82.9%
D	15	6.9%
Blank	0	0.0%
Sum	216	100.0%

Rating	POST Confidence	
1	9	4.2%
2	12	5.6%
3	67	31.0%
4	54	25.0%
5	67	31.0%
Blank	7	3.2%
Sum	216	100.0%

Pretest/Posttest Open-Response Items #5-7

Score	Pre 5	
0	42	19.4%
1	16	7.4%
2	15	6.9%
3	7	3.2%
4	2	0.9%
Blank	134	62.0%
Sum	216	100.0%
Mean	0.35	

Post 5	
5	2.3%
3	1.4%
13	6.0%
19	8.8%
167	77.3%
9	4.2%
216	100.0%
3.49	

Confid	Pre 5	
Total	216	
1	148	68.5%
2	9	4.2%
3	5	2.3%
4	4	1.9%
5	24	11.1%
Blank	26	12.0%
Sum	216	100.0%

Post 5	
216	
10	4.6%
10	4.6%
39	18.1%
61	28.2%
83	38.4%
13	6.0%
216	100.0%

Score	Pre 6	
0	35	16.2%
1	24	11.1%
2	1	0.5%
3		
4		
Blank	156	72.2%
Sum	216	100.0%
Mean	0.12	

Post 6	
40	18.5%
147	68.1%
17	7.9%
12	5.6%
216	100.0%
0.84	

Confid	Pre 6	
Total	216	
1	135	62.5%
2	9	4.2%
3	11	5.1%
4	8	3.7%
5	23	10.6%
Blank	30	13.9%
Sum	216	100.0%

Post 6	
216	
6	2.8%
12	5.6%
50	23.1%
64	29.6%
60	27.8%
24	11.1%
216	100.0%

Score	Pre 7	
0	44	20.4%
1	25	11.6%
2	10	4.6%
3	8	3.7%
4		
Blank	129	59.7%
Sum	216	100.0%
Mean	0.32	

Post 7	
63	29.2%
52	24.1%
21	9.7%
35	16.2%
45	20.8%
216	100.0%
0.92	

Confid	Pre 7	
Total	216	
1	141	65.3%
2	12	5.6%
3	11	5.1%
4	2	0.9%
5	15	6.9%
Blank	35	16.2%
Sum	216	100.0%

Post 7	
216	
45	20.8%
27	12.5%
56	25.9%
24	11.1%
33	15.3%
31	14.4%
216	100.0%

Lab Exam, EKG Lab Items 1-3

Score	Exam 1	
0	4	1.9%
1	74	34.3%
2	32	14.8%
3	106	49.1%
4		
Blank	0	0.0%
Sum	216	100.0%
Mean	2.11	

Exam 2	
32	14.8%
110	50.9%
74	34.3%
0	0.0%
216	100.0%
1.19	

Exam 3	
11	5.1%
26	12.0%
36	16.7%
87	40.3%
41	19.0%
15	6.9%
216	100.0%
2.42	