

# Electromagnetic Waves

Waves composed of undulating electrical fields and magnetic fields. The different kinds of electromagnetic waves, such as light and radio waves, form the electromagnetic spectrum. All electromagnetic waves have the same speed in a vacuum, a speed expressed by the letter  $c$  (the speed of light) and equal to about 186,000 miles (or 300,000 kilometers) per second.

Transmission of energy through a vacuum or using no medium is accomplished by **electromagnetic waves**, caused by the oscillation of electric and magnetic fields. They move at a constant speed of  $3 \times 10^8$  m/s. Often, they are called **electromagnetic radiation, light, or photons**.

Fundamental Question:

For two charges  $q$  and  $Q$  the strength of attraction depends on distance between both charges (Coulombs Law). Now we grasp charge  $Q$  and jiggle it around. The jiggling causes the distance and therefore attraction to vary.

How does charge  $q$  know that I am jiggling charge  $Q$ ?

We create a disturbance which launches an electromagnetic wave into the universe. The wave tells the Universe we generated an electric disturbance which propagates away from the point of the disturbance

→ **Electromagnetic radiation**

(Predicted by Clerk Maxwell (1831-1879) in 1864)

The faster we jiggle the charge the shorter the wavelength

**Maxwell's theory** is a mathematical formulation that relates electric and magnetic phenomena.

His theory, among other things, predicted that **electric and magnetic fields can travel through space as waves.**

The uniting of electricity and magnetism resulted in the **Theory of Electromagnetism.**

**Maxwell predicted (in 1864!):**

- A changing electric field produces a magnetic field.
- **Accelerating charges** will radiate electromagnetic waves.
- Electromagnetic waves travel at the speed of light  $c$ :  
 $c \approx 3 \times 10^8 \text{ m/s}$
- The electric and magnetic fields in the wave are fluctuating.

**In 1887, Heinrich Hertz** generated and detected electromagnetic waves in his lab.

The waves radiated from a transmitter circuit and were detected in a receiver circuit.

Hertz used the fact that electrical circuits have resonant frequencies just like mechanical systems do.

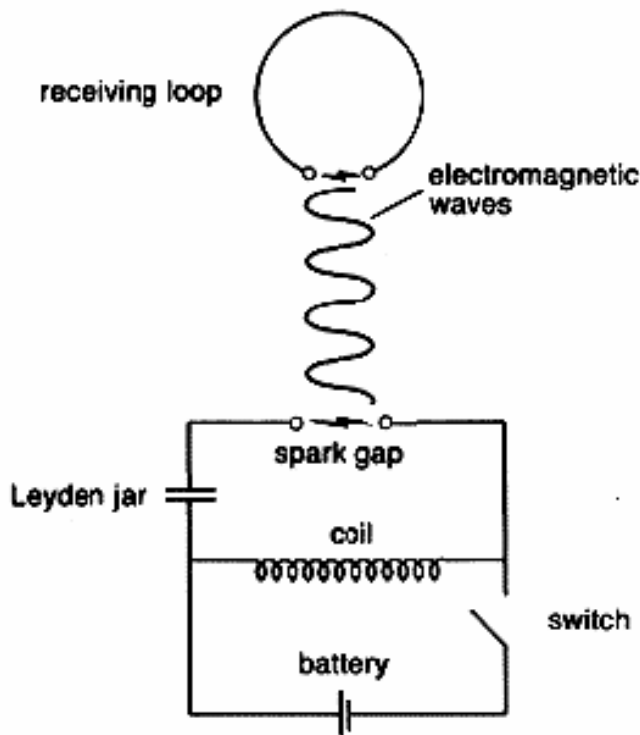

**Conceptual Schematic of Hertz's Experiment**

## A traveling electromagnetic wave produced by an ac generator attached to an antenna

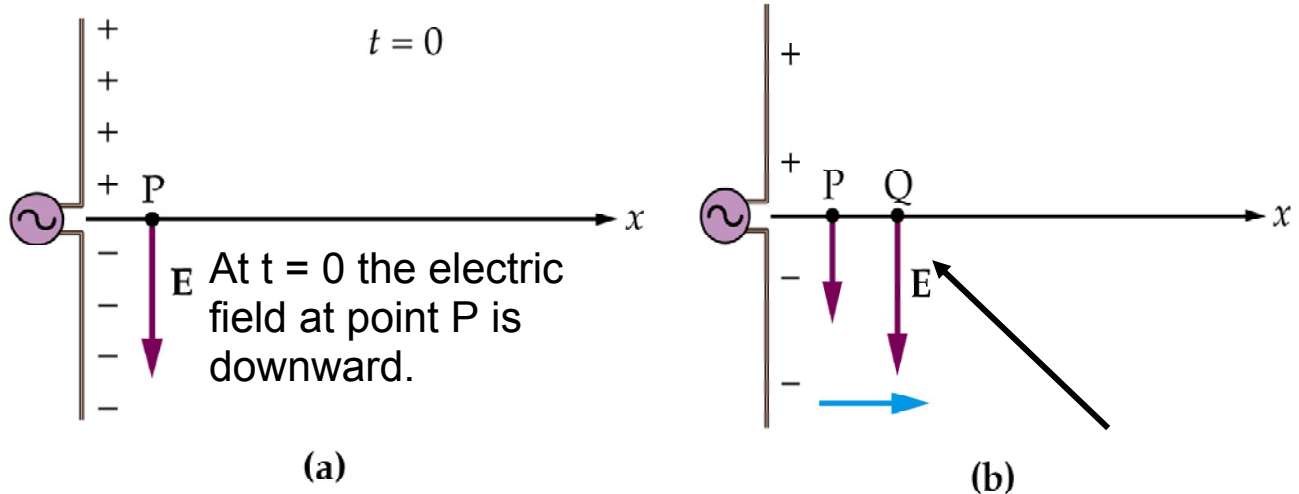

A short time later the electric field at P is still downward, but now with a reduced magnitude. Note that the field created at  $t = 0$  has moved to point Q. The decreasing electric field at point P creates a magnetic field at point Q pointing into the viewgraph

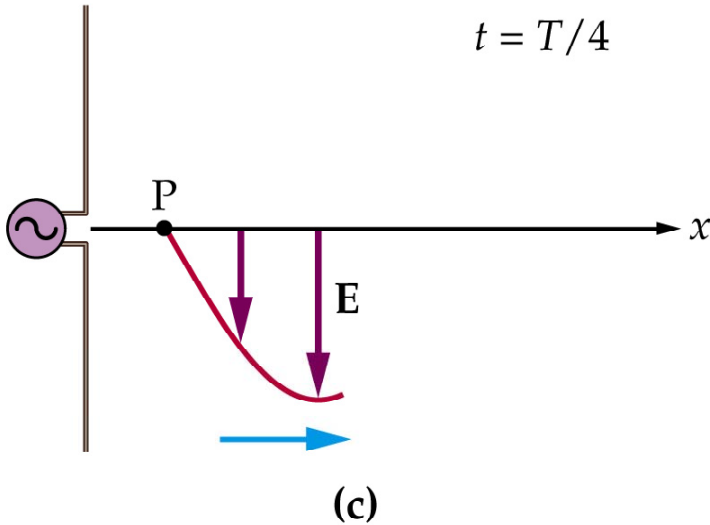

After one quarter of a cycle, at  $t = 1/4 T$ , the electric field at P vanishes.

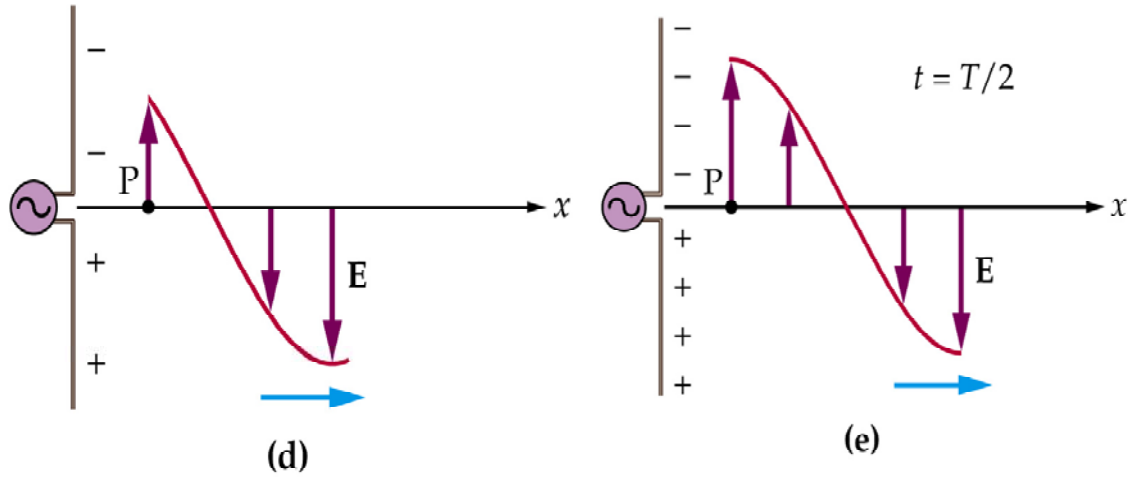

The charge on the antenna has reversed polarity now, and the electric field at P points upward.

When the oscillator has completed half a cycle,  $t = 1/2 T$ , the field at point P is upward and of maximum magnitude.

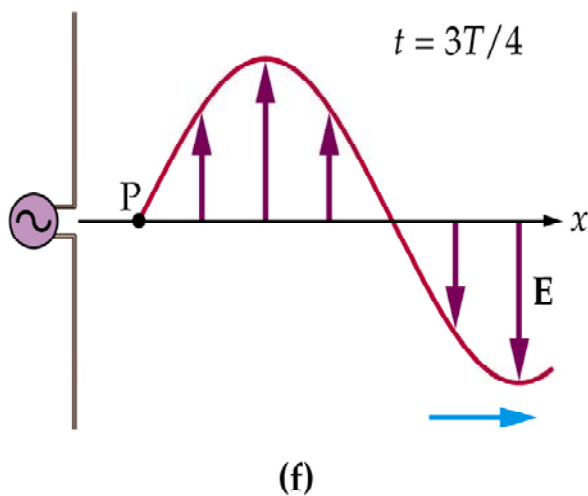

At  $t = 3/4 T$  the field at P vanishes again. The fields produced at earlier times continue to move away from the antenna.

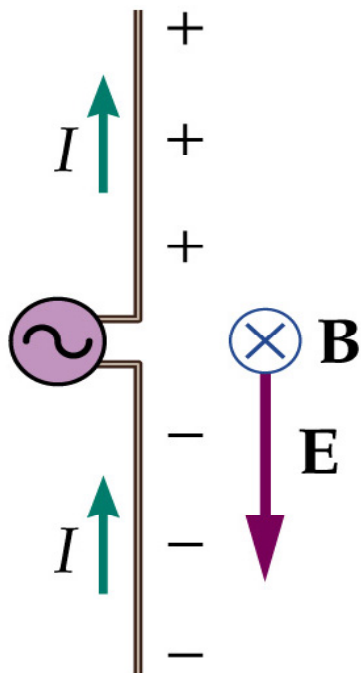

When the electric field produced by the antenna points downward, the magnetic field points into the page. The electric and magnetic fields in an electromagnetic wave are always at right angles to each other.

### Right Hand Rule:

An electromagnetic wave propagating in the positive  $x$  direction:  $\vec{E}$  and  $\vec{B}$  are perpendicular to each other and in phase. The direction of propagation is given by the thumb of the right hand, after pointing the fingers in the direction of  $\vec{E}$  and curling them toward  $\vec{B}$  (palm towards  $\vec{B}$ ).

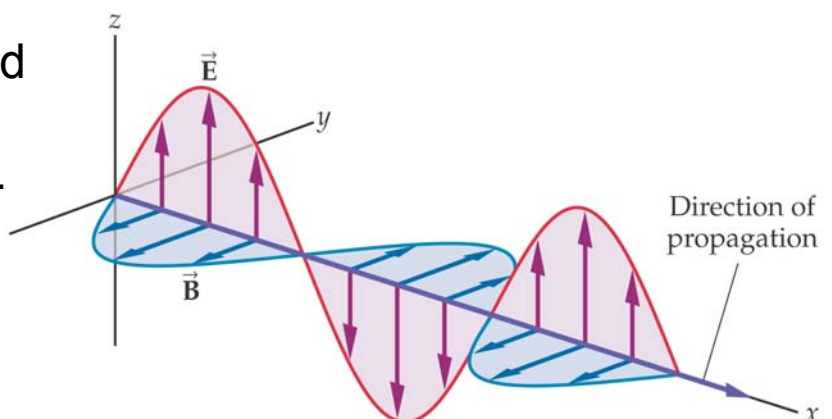

# Properties of EM Waves

The radiated EM waves have certain properties:

- EM waves all travel at the speed of light  $c$ .  
$$c^2 = 1/(\epsilon_0\mu_0)$$
- The E and B fields are perpendicular to each other.
- The E and B fields are **in phase** (both reach a maximum and minimum at the same time).
- The E and B fields are perpendicular to the direction of travel (**transverse waves**).

# Receiving radio waves

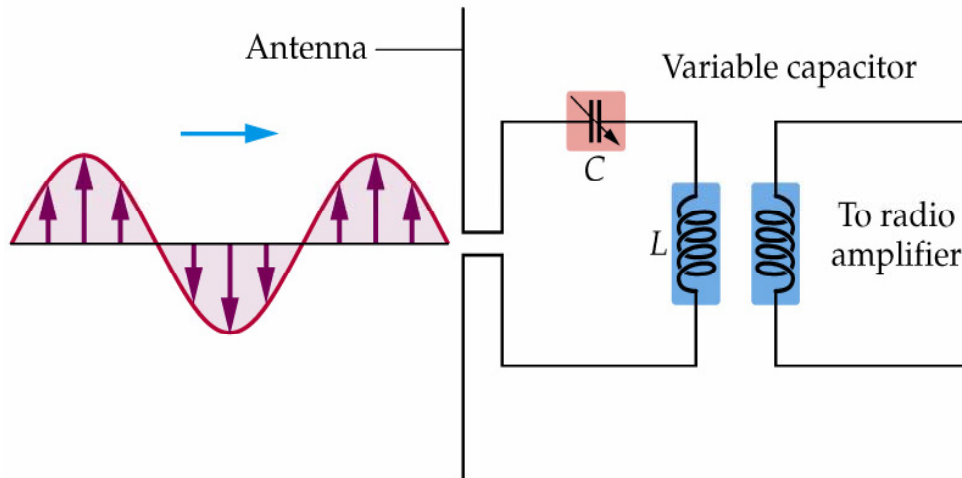

Basic elements of a tuning circuit used to receive radio waves. First, an incoming wave sets up an alternating current in the antenna. Next, the resonance frequency of the LC circuit is adjusted to match the frequency of the radio wave, resulting in a relatively large current in the circuit. This current is then fed into an amplifier to further increase the signal.

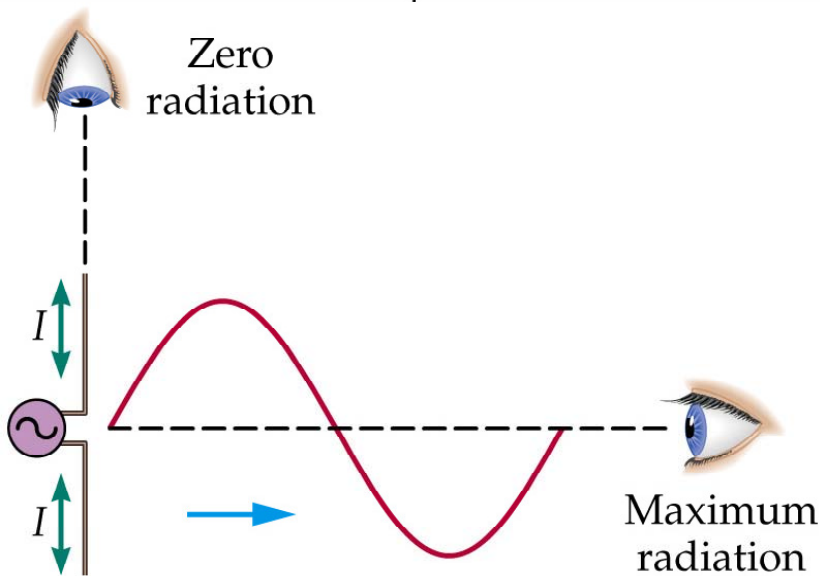

Electromagnetic radiation is greatest when charges accelerate at right angles to the line of sight. Zero radiation is observed when the charges accelerate along the line of sight.

# Plane Waves

EM waves in free space are **plane waves**. That means the E and B fields are confined to a plane and uniform within the plane at all times.

EM waves travel at the speed of light. Light speed can be derived from two other quantities we have already used:

$$c = \frac{1}{\sqrt{\epsilon_0 \mu_0}} \equiv 2.99792458 \times 10^8 \frac{m}{s} \quad c = \frac{1}{\sqrt{\mu_0 \epsilon_0}}$$

---

# Light

Light is an electromagnetic wave

$$c = \lambda f \approx 3 \times 10^8 \text{ m/s}$$

As light waves travel through space they:

» **transport energy**

» **transport momentum**

The energy density,  $u$ , of an electromagnetic wave:

$$u = \frac{1}{2} \epsilon_0 E^2 + \frac{1}{2\mu_0} B^2 = \epsilon_0 E^2 = \frac{1}{\mu_0} B^2$$

$$E = cB$$

---

# Walker Problem 42, pg. 846

What is the rms value of the electric field in a sinusoidal electromagnetic wave that has a maximum electric field of  $75 \text{ V/m}$ ?

---

EM waves can be generated in different frequency bands:  
radio, microwave, **infrared**, **visible**, **ultraviolet**, x-rays, gamma rays

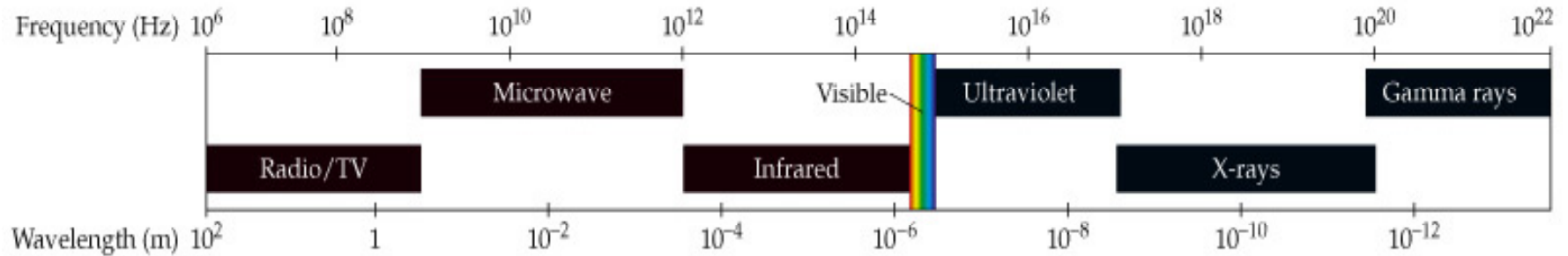

Note that the visible portion of the spectrum is relatively narrow.  
The boundaries between various bands of the spectrum are not sharp, but instead are somewhat arbitrary.

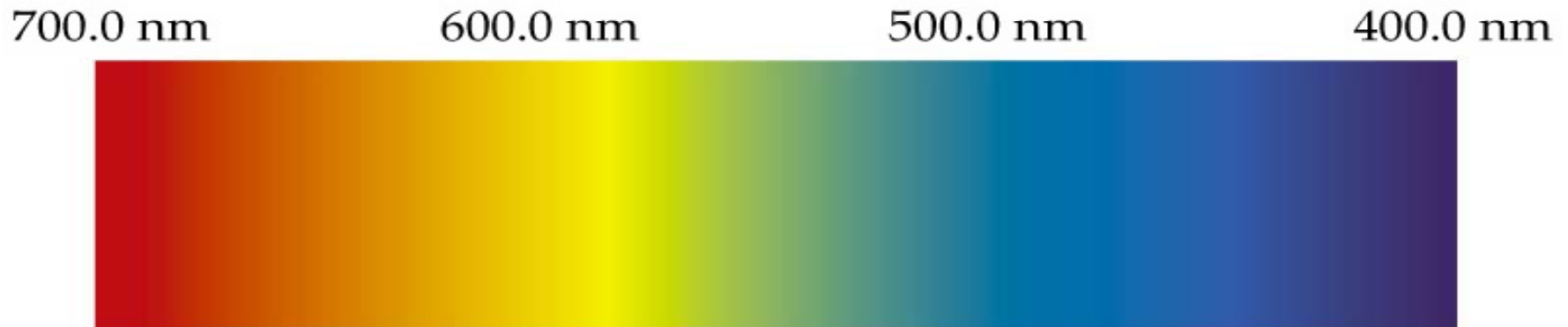

## Walker Problem 26, pg. 845

Find the frequency of blue light with a wavelength of 470 nm.

## Walker Problem 38, pg. 846

As you drive by an AM radio station, you notice a sign saying that its antenna is 122 m high. If this height represents one quarter-wavelength of its signal, what is the frequency of the station?

---

[Radio \(0.4 GHz\)](#)

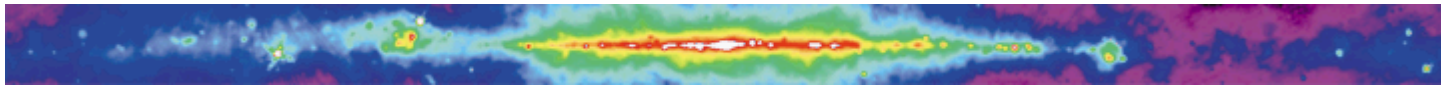

[Atomic Hydrogen](#)

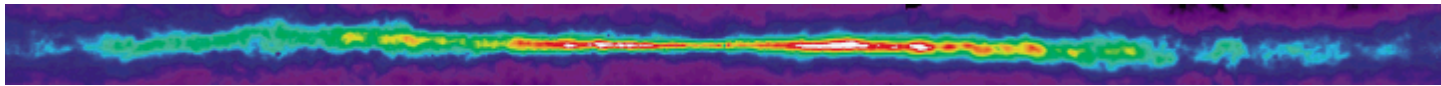

[Radio \(2.7 GHz\)](#)

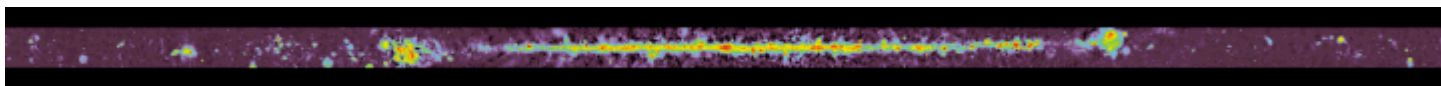

[Molecular Hydrogen](#)

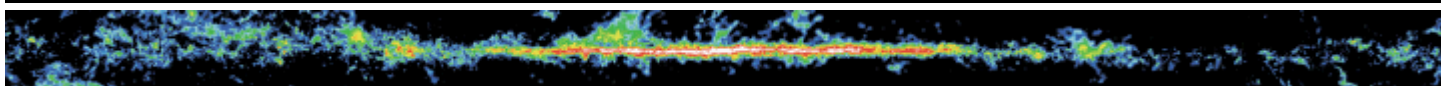

[Infrared](#)

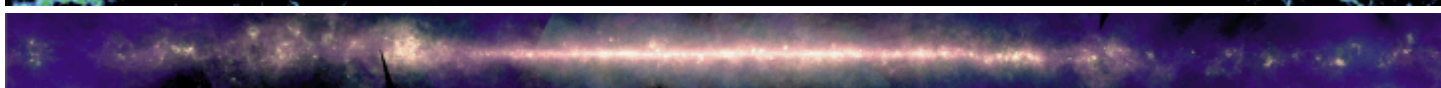

[Mid Infrared](#)

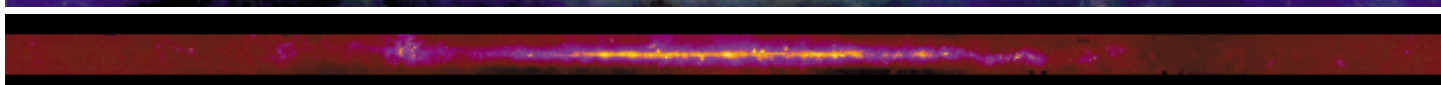

[Near Infrared](#)



[Optical](#)



[X-Ray](#)

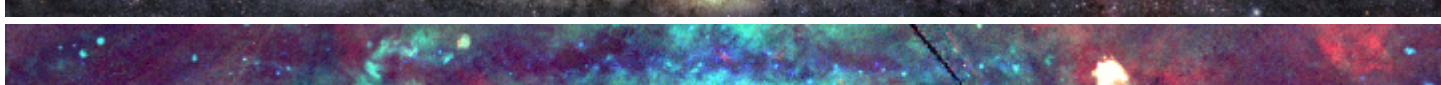

[Gamma Ray](#)

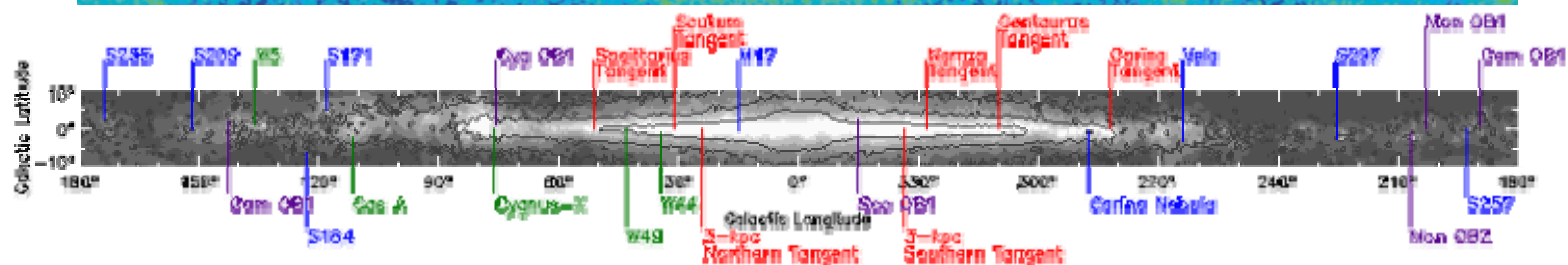
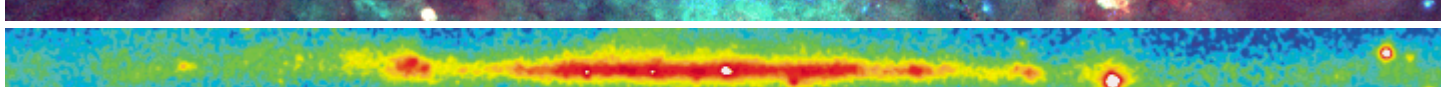

[Finder](#)

From <http://adc.gsfc.nasa.gov> Galactic latitude is measured from the galactic plane (Earth latitude is measured from the equator), and galactic longitude is measured from the direction to the galactic center (Earth longitude is measured from London's Greenwich Observatory).

## The Doppler effect

$$f' = f \sqrt{\frac{c + u}{c - u}}$$

### Red-shifts and the Expansion of the Universe:

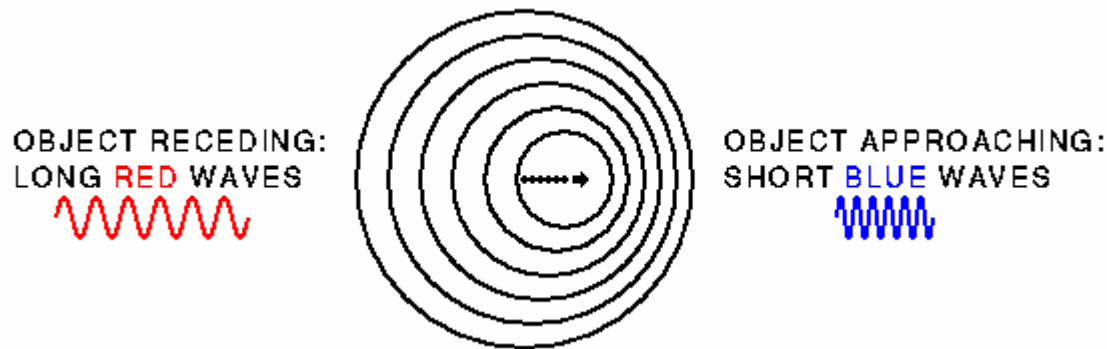

We can observe features in the spectra obtained from distant galaxies and compare their wavelengths/frequencies with those measured in the laboratory. We find that, apart from galaxies within our Local Group (such as the Andromeda spiral), the light **from distant galaxies has been "red-shifted"** - the wavelengths of spectral lines are longer than those measured on Earth **SO THESE GALAXIES ARE MOVING AWAY FROM US**. This is a consequence of the general expansion of the Universe: all clusters of galaxies are moving away from each other

Example:

A space ship heading towards a stop light – red = 750nm – see the light to be shifted to green = 500nm. What is the speed of the space ship?

$$f \lambda = c$$

$$\text{Now } \frac{c}{\lambda'} = \frac{c}{\lambda} \sqrt{\frac{c+u}{c-u}}$$

So we solve for  $u$  in the lower equation.

# Polarization

When light is polarized, the electric field always points in the same direction.

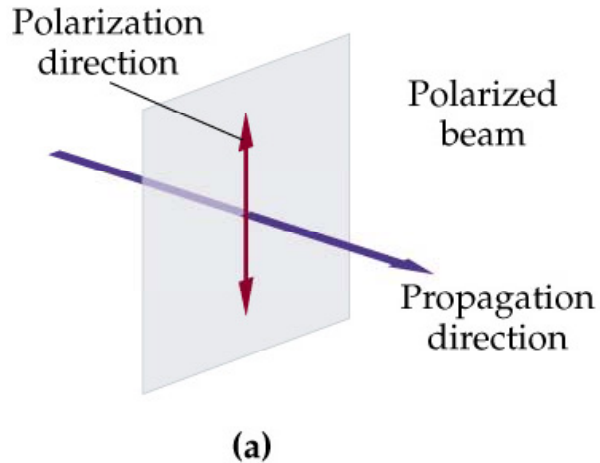

A beam of light that is:

- *polarized in the vertical direction*: The electric field points in the vertical direction.

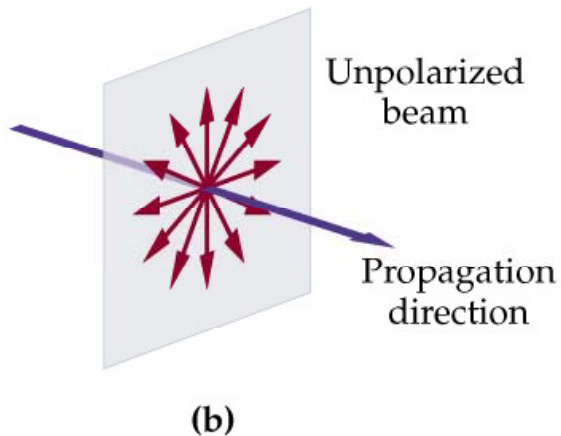

- (b) *unpolarized*: Superposition of many beams, approximately parallel, but each with random polarization. Every atom in the filament of an incandescent bulb radiates a separate wave with random phase and random polarization.

# Polarizer

$$I = I_0 \cos^2 \theta$$

Law of Malus

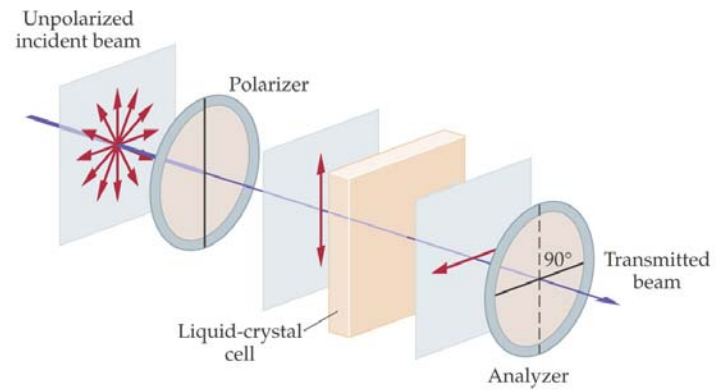
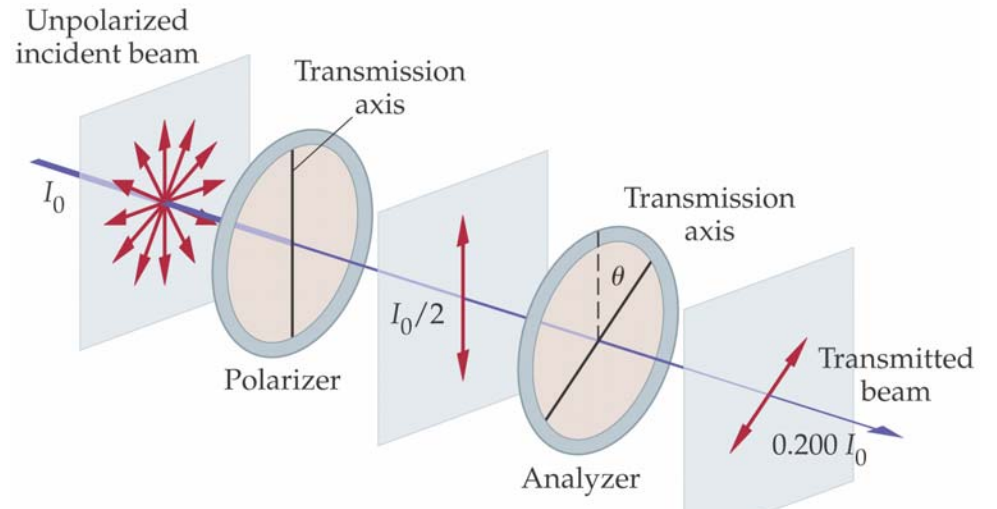
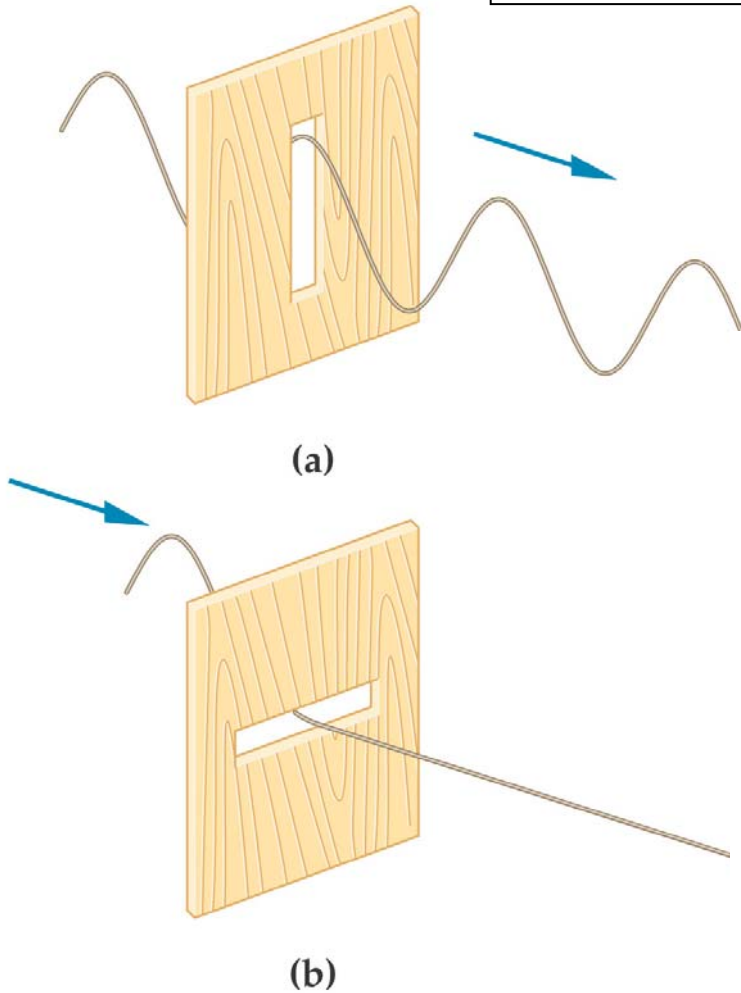

(a) Off

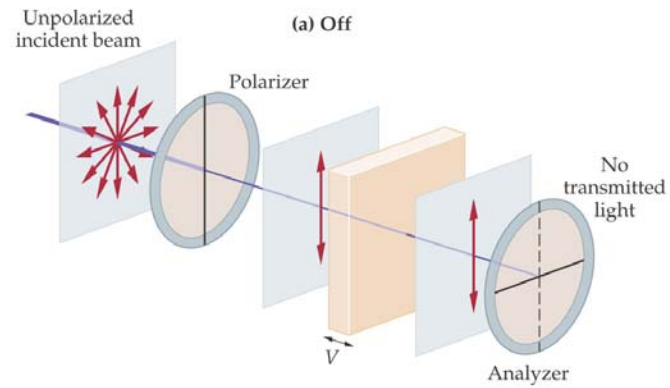

(b) On

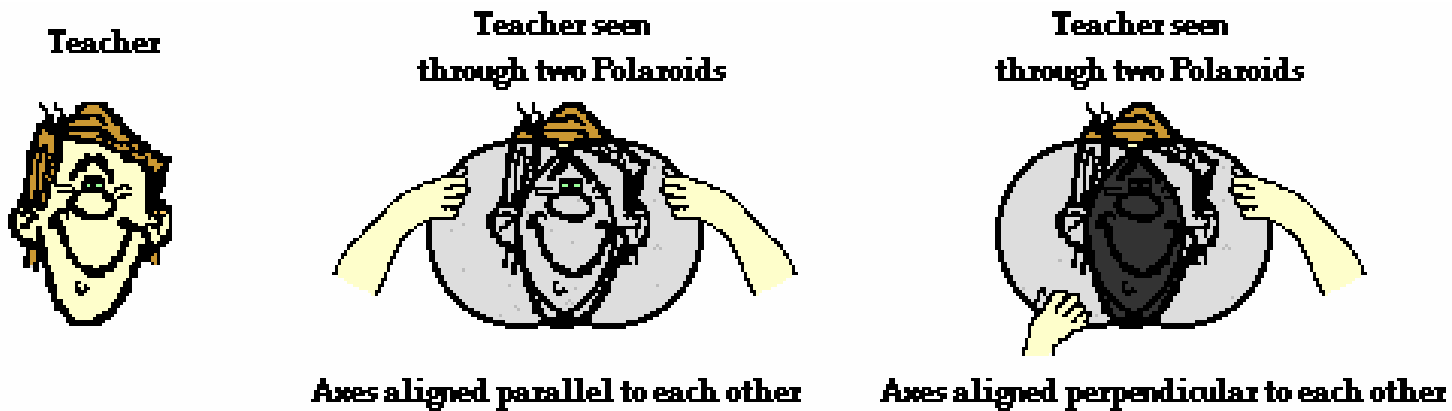

## Polarization by Scattering or Reflection

Polarization is also used in the entertainment industry to produce and show 3-D movies!

